

- SANDRINGHAM YACHT CLUB -

# *Off the Wind*

2023 MEDIA KIT



# The official Journal of the Sandringham Yacht Club provides the eagerly awaited season review for club members.



>> Front Cover



>> Inside Pages

# PUBLICATION OVERVIEW

***Off the Wind* is the official Journal of the Sandringham Yacht Club and provides our clients with direct and exclusive access to over 3,000 members, associates and guests of Victoria's premier yacht club.**

SYC is situated on the foreshore of Port Phillip Bay. Offering world class sailing facilities, year round sporting and social events, exceptional dining rooms, 360 berth floating marina, boating academy, waterfront support services and a modern clubhouse.

SYC members and their guests enjoy a lively club atmosphere thanks to year round industry events, boating activities and sailing regattas. Members are affluent, progressive and aspirational.

*Off the Wind* delivers the latest, most relevant information on race results, events, membership, sailing equipment and general club life updates.

Published annually, *Off the Wind* is distributed to the SYC Membership and stakeholders in hard copy or electronically. It is also issued to SYC annual intake of 200+ New Members as well as being made available throughout the year in SYC Clubhouse. The hard copy is published in high quality gloss stock. The electronic version is available as a pdf and easily viewed or downloaded from [syc.com.au](http://syc.com.au).

*Off the Wind* is reflective of the exclusivity of the Club and the marquee brands of our clients.



*"Sandringham Yacht Club is the premier yacht club in Victoria and has been in operation for over 100 years, offering excellent facilities, very active year round boating and social programs and in a wonderful location complimented by resources to ensure that your needs are met both on water and land."*



## Key Facts

- High-end market
- Broad cross-section of business people
- Clubhouse and its facilities are world class
- Reviews past season
- Distribution Australia wide.

## Advertising Rate Card and Dimensions

SIZE	HEIGHT x WIDTH	MEMBER & SPONSOR RATE	NON MEMBER RATE
Quarter Page Horizontal	63 x 181 mm	\$500	\$575
Quarter Page Vertical	131 x 89 mm	\$500	\$575
Half Page	131 x 181 mm	\$900	\$1035
Full Page	297 x 210 mm	\$1,800	\$2,070
Inside Front Cover	297 x 210 mm	\$2,200	\$2,530
Inside Back Cover	297 x 210 mm	\$2,200	\$2,530
Outside Back Cover	297 x 210 mm	\$2,500	\$3,000
Double Page Spread	297 x 429 mm	\$2,500	\$3,000

*\*All rates include full colour. Prices shown above are exclusive of GST.*

## Advertising Booking and Material Deadlines

BOOKING DEADLINE	ARTWORK DEADLINE	DISTRIBUTION DATE
1 September 2023	11 September 2023	Mid-November 2023

*\*If you don't have existing artwork, please see page 4 of the Media Kit for advert creation services from Privaro Design.*

## Visual Guide

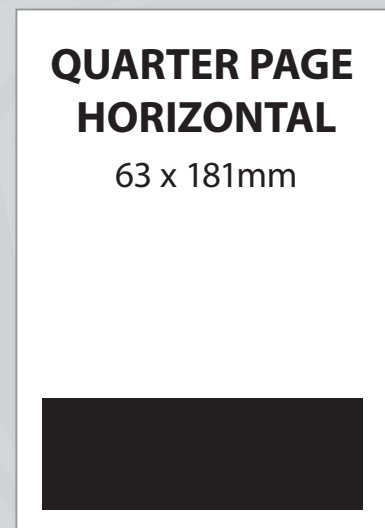
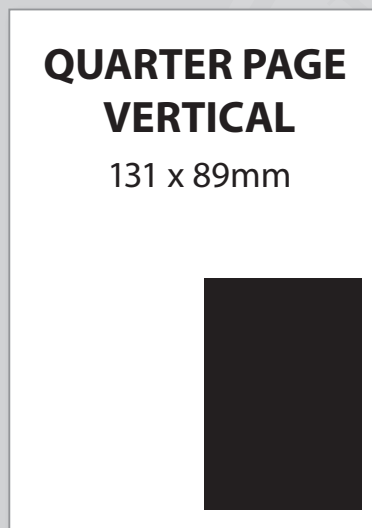
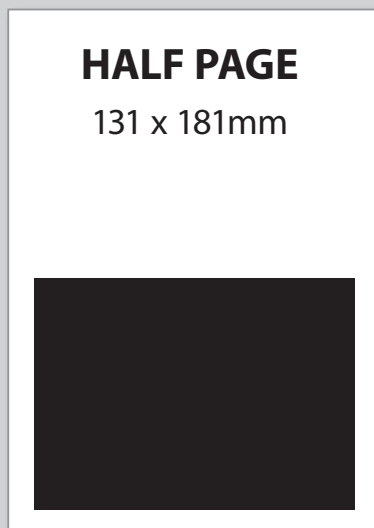

# Artwork Specifications

## COLOURS

- Process CMYK for full colour, greyscale or black & white for mono reproduction.
- No PMS or spot colours.
- Images requiring colour correction may not be accepted.
- For accurate colour reproduction, all material must be accompanied by a digital proof.
- No responsibility will be taken for print colour reproduction if a proof is not supplied.

## IMAGE RESOLUTION

- All images must be 300dpi resolution at 100% scaling.
- Lower resolution images will not be accepted.

## TYPE FORMATS

- Type should be no smaller than 8pt.
- All fonts embedded and/or outlined.
- No 'TrueType' fonts will be accepted.
- Register and Trim marks must appear on all files.
- Minimum 3mm bleed where required.

## ACCEPTABLE MEDIA

- Please supply a high-resolution, print-ready PDF file with 3mm bleed and crop marks, ensure all fonts are outlined, any PMS Spot colours and RGB images are converted to CMYK.
- Ensure file is labelled with your business name along with type of ad booked. eg. Businessname\_halfpageAdv.pdf.
- All adverts to be emailed to: **Andrea.Seignior@syc.com.au**
- Adverts over 10Mb please use an online file sharing website 'Dropbox', please contact **Nick Richards** (nick@privaro.com.au) for login details.

## DISCLAIMER

While we may verify that advertising material is within our specifications, it is the responsibility of the client/agency to supply correct material. It is also a requirement that the material must be delivered on time so quality checking procedures can take place. Late and/or incorrect materials are liable to incur additional production charges.

Sandringham Yacht Club reserves the right to refuse any advertising material that is in conflict of any Club stakeholder and the right to refuse any advertising material that does not meet our print specifications.

# Editorial, Advertising & Design Enquiries

## EDITORIAL

Editorial can be submitted for consideration, please email:

**Andrea.Seignior@syc.com.au**

Subject to editor's discretion.

Acceptance of an article does not guarantee publication.

## ADVERTISING ENQUIRIES

For all advertising enquiries please call **Andrea Seignior**, Sandringham Yacht Club

**P: (03) 9599 0999**

**E: Andrea.Seignior@syc.com.au**

**W: syc.com.au**

## DESIGN ENQUIRIES

For all print design enquiries please contact :

**Nick Richards**

Director

Privaro Design

**M: 0408 159 355**

**E: nick@privaro.com.au**

**W: privaro.com.au**

