

WW Winter Series Race 13 Musketeers beat the Adrenalin Rush

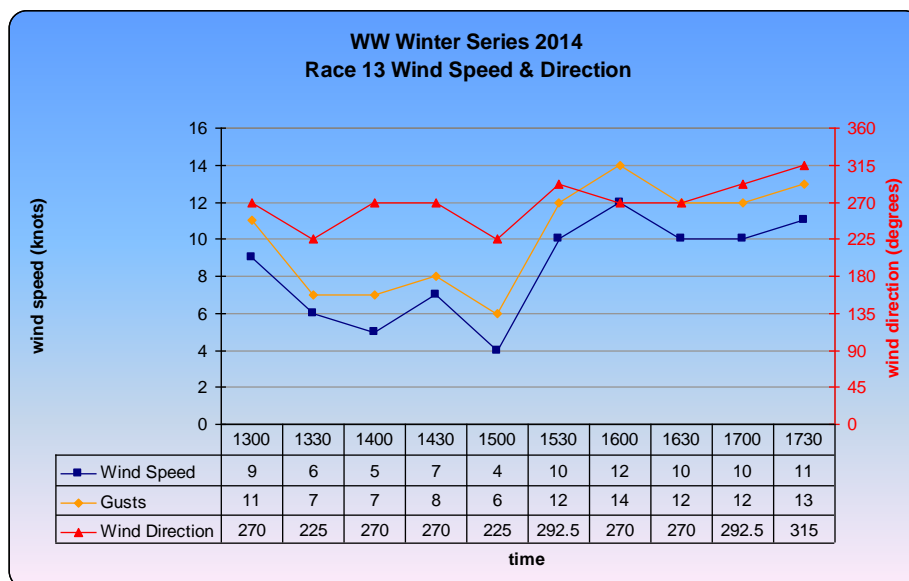

The start of the second half of the 2014 Winter Series race 13 became an intriguing contest with light and variable breezes giving one yacht then another an unexpected advantage. The breeze eased as the start approached and it seemed that even a shortened 9.8 mile course 16 would prove too long for some if not all of the 36 yacht fleet. However, by about 1500 the breeze began to increase becoming westerly before moving further north. Any fears of an abandoned race proved to be unfounded as the winner crossed the line before 1630, extending the race by 30 minutes and allowing all the fleet that included three visitors to finish a shortened course. The end of the race brought an unexpected twist with the news that 6 yachts had crossed the line too soon.



Post race celebrations may have been tinged with disappointment for these six yachts. Two of the six, MY WAY (Magdy Iskander) and INSX (Rob Sills) started more than a minute early and recorded DNS. The remaining four yachts were each penalized 5 minutes – a penalty that took a heavy toll in this race. ADRENALIN (I.Beer & A.Molnar) finished 10th after crossing the line in 1st place. TEQUILA (Alan Collins) went from 7th across the line to finish 20th; UPBEAT (Peter Dunne) from 8th to 21st; and, WHITE NOISE (Daniel Edwards) from 12th to 22nd.



It was the Beneteau 44.7 MUSKETEER (Paul Jacka) who won race 13 crossing the finish line at 16:00:40. She was leading the fleet approaching the northern end of the breakwater but a rush of ADRENALIN put her 2nd across the line. However, ADRENALIN had started too soon; penalized 5 minutes leaving MUSKETEER the winner. This was MUSKETEER'S first win from 6 completed races this series and puts her in 12th place in the aggregate. MUSKETEER started the race 33 seconds late for her 47 minute handicap from 3rd last position. She sailed the course in 1:43:40 - the fastest time of the day.

RACE RECORD - MUSKETEER									
RACE	DATE	POSN	ELAPSED	FINISH	HCAP	SOD	COURSE	DISTANCE	WIND SPEED
2	16/04/2014	14	01:44:17	16:01:17	00:47:00	3	65	8.6	8
3	23/04/2014	10	02:10:52	16:25:52	00:45:00	93	63	6	4
5	7/05/2014	3	01:51:09	16:06:09	00:45:00	6	62	9.5	9
8	28/05/2014	31	01:27:04	15:44:04	00:47:00	300	31	8.8	15
9	4/06/2014	3	01:34:02	15:49:02	00:45:00	19	6	8.4	9
13	2/07/2014	1	01:43:40	16:00:40	00:47:00	33	16	6.1	8



In 2nd place was the Bavaria 42 BARNSTORMER (Brian Barnes) achieving her best result of the series so far beating her 3rd place in race 3. BARNSTORMER started from 26th place only 3 seconds late for a 42 minute start. She sailed the course in 1:49:25 and crossed the line at 16:01:25. BARNSTORMER has completed 8 races and finished in the top ten on 3 occasions and sits in 10th place in the aggregate.

RACE RESULT - BARNSTORMER									
RACE	DATE	POSN	ELAPSED	FINISH	HCAP	SOD	COURSE	DISTANCE	WIND SPEED
1	9/04/2014	10	01:24:17	15:39:17	00:45:00	1	6	8.4	8
2	16/04/2014	22	01:47:33	16:03:33	00:46:00	3	65	8.6	8
3	23/04/2014	3	02:09:20	16:23:20	00:44:00	12	63	6	4
4	30/04/2014	28	01:42:25	15:57:25	00:45:00	5	14	9.8	15
9	4/06/2014	8	01:36:57	15:50:57	00:44:00	12	6	8.4	9
10	11/06/2014	21	01:36:10	15:51:10	00:45:00	19	61	9.8	18
12	25/06/2014	11	01:19:29	15:31:29	00:42:00	12	31	8.8	18
13	2/07/2014	2	01:49:25	16:01:25	00:42:00	3	16	6.1	8

PUBLIC BAR (Clive Sondheim) is one of 3 yachts to have completed 11 races this series and this 3rd place is her 2nd podium finish. She crossed the finish line at 16:01:37 after sailing the course in 1:49:37 the 6th fastest time of the day. She was the 28th yacht to start the race 20 seconds late for a 42 minute handicap. She is 3rd in the aggregate.



RACE RECORD – PUBLIC BAR									
RACE	DATE	POSN	ELAPSED	FINISH	HCAP	SOD	COURSE	DISTANCE	WIND SPEED
1	9/04/2014	6	01:23:45	15:37:45	00:44:00	2	6	8.4	8
2	16/04/2014	27	01:49:20	16:05:20	00:46:00	13	65	8.6	8
3	23/04/2014	1	02:04:54	16:18:54	00:44:00	15	63	6	4
4	30/04/2014	36	01:43:03	16:00:03	00:47:00	12	14	9.8	15
5	7/05/2014	19	02:01:57	16:17:57	00:46:00	4	62	9.5	9
6	14/05/2014	30	01:43:32	15:58:32	00:45:00	15	61	9.8	16
8	28/05/2014	28	01:25:31	15:40:31	00:45:00	9	31	8.8	15
9	4/06/2014	5	01:36:27	15:49:27	00:43:00	15	6	8.4	9
10	11/06/2014	20	01:36:47	15:50:47	00:44:00	55	61	9.8	18
12	25/06/2014	9	01:18:51	15:30:51	00:42:00	10	31	8.8	18
13	2/07/2014	3	01:49:37	16:01:37	00:42:00	20	16	6.1	8



There had only been three previous cases of STS (starting too soon) in the series so far but race 13 experienced a sudden outbreak of this dreadful phenomenon that affected six yachts. This tended to detract from what was a good start with 29 yachts starting within 35 seconds or less of their start times. There were joint winners of Start of the Day with both AQUA BELLA



(Geoffrey Simpson) and PRIMO (Steve Copley) taking the honours. WINDSPEED (Les Browne) and BARNSTORMER were only 1 second behind.

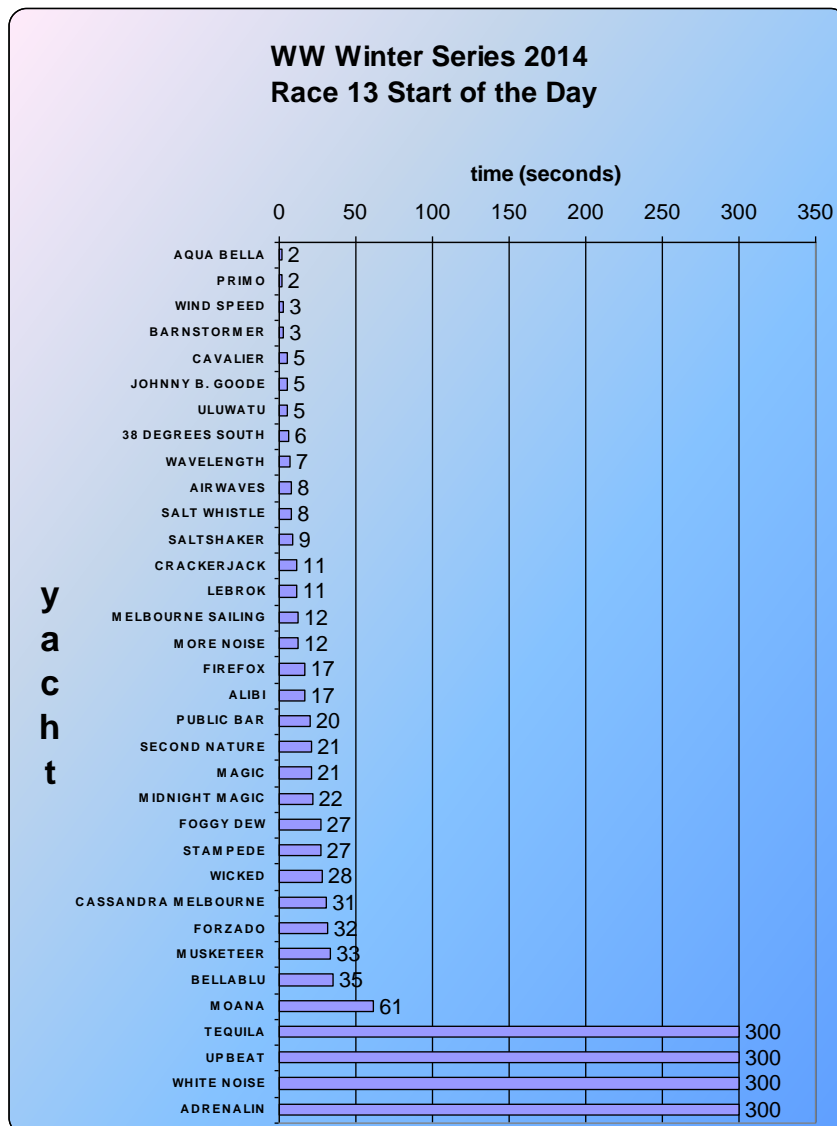

The race started with the fleet 48 minutes apart and closed up to finish 34 minutes 31 seconds apart. The first 30 of the 34 finishers finished the race within 14 minutes 47 seconds of each other.

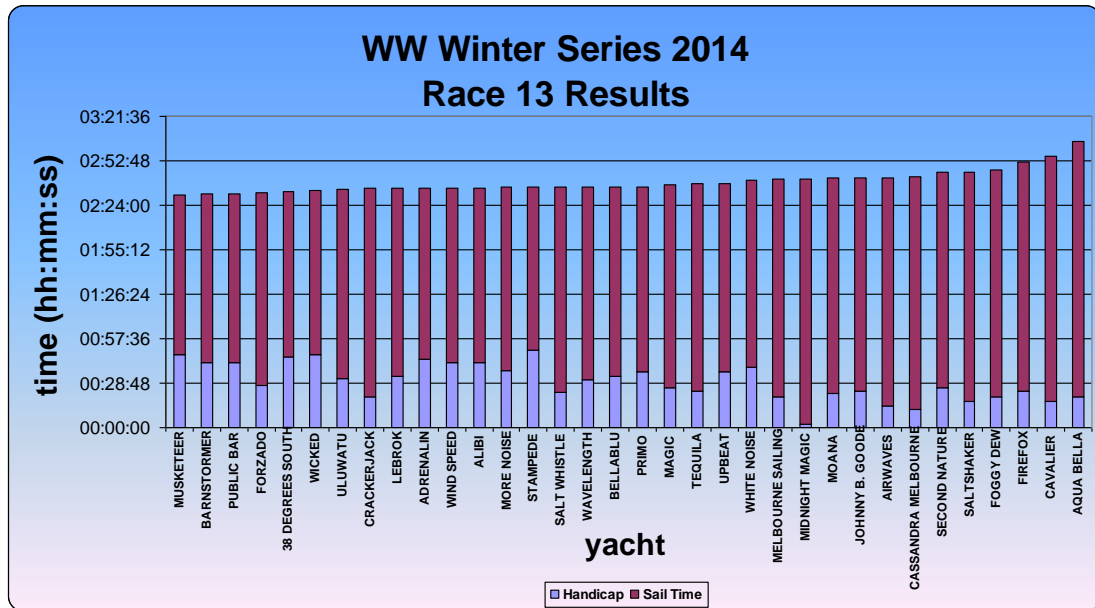

Only one of the early starters finished amongst the first third of the fleet to complete the race. On the other hand seven of the last eleven yachts to start the race finished amongst the first eleven finishers.

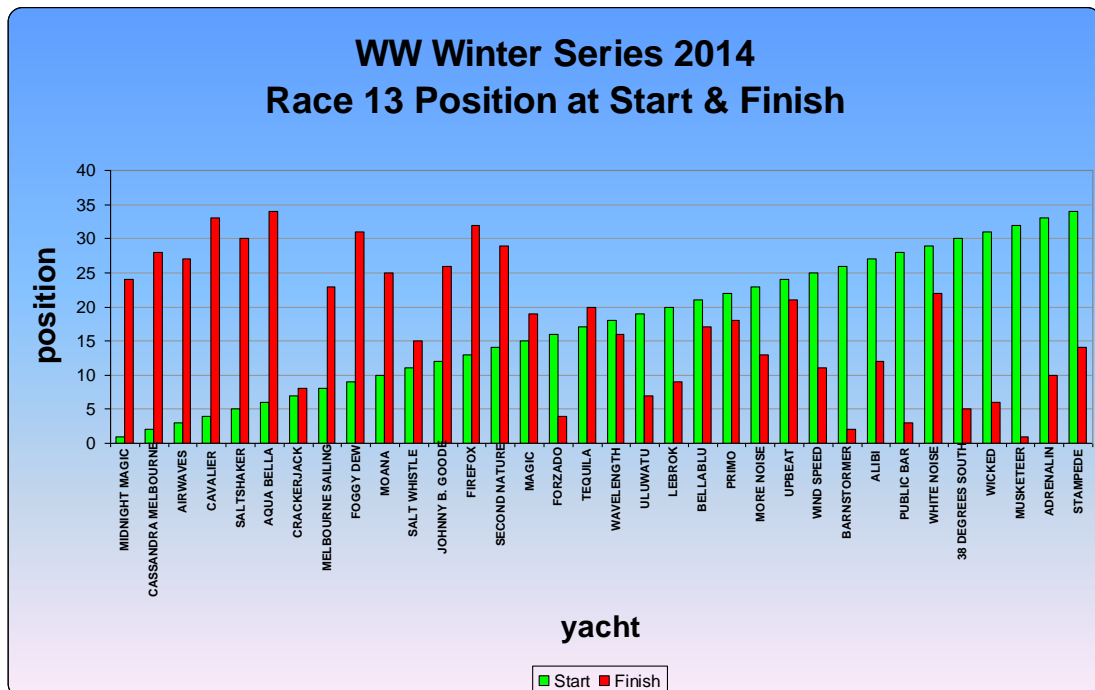

All thirteen scheduled races have been started this series but two were abandoned without a yacht completing the course within the specified time. An average of 31 yachts has contested each race. Four courses have been

shortened and the average rhumb line distance sailed has been 8.5 miles around 8 different courses. The average wind speed in last years (2013) winter series was 14 knots 3 knots more than the average wind speed of 11 knots in the current series. All in all a tight contest is emerging in the handicap with only 15 points covering 11 yachts.

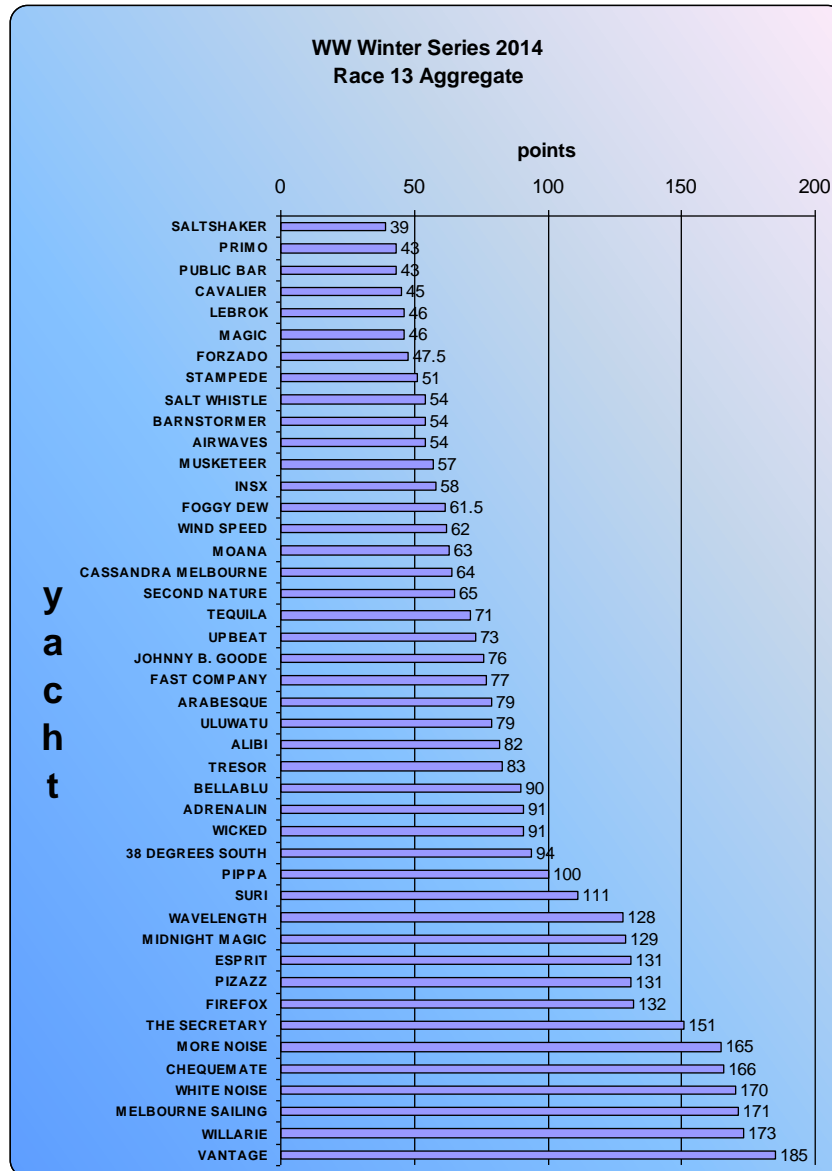

Windward Buoy

The Mark Windward Bequest

Going in Circles

A number of people would have noticed 38 DEGREES SOUTH carrying out a 720 in the vicinity of number 2 last Wednesday. It was a particularly well executed manoeuvre and looked very artistic. It was performed

without interfering with other yachts; in clear water; very quick and in a tight turning circle. 38° would not have improved her race position as a result of the manoeuvre but may not have lost much either. Could a larger cruising style of yacht, perhaps MOANA or ULUWATU for example, carry out such a manoeuvre so quickly? Could a smaller lighter yacht, a J24 for example, do it quicker? If there are significant differences in the time taken by different yachts to carry out a 360 or 720 are the rules fair and equitable to all competitors in a keel boat race? (Time for a cup of tea and a lie down).

Quiz Race 12 + Apology

The question asked in race 12 was a photo question submitted by Mark Windward who asked "Where do you think this could be?"



Unfortunately Mark did not provide a precise answer hence the apology. However, there has been one response to the question which is in the right area. (Mark went on a river/canal cruise from Moscow to St Petersburg. He may provide a more precise answer next week in the meantime any further replies to

mark-windward@live.com.au

Quiz Question Race 13

The question for this week is provided by "the Anonymous Scribe". This monitor class ship has been described as possibly the worst warship ever designed.

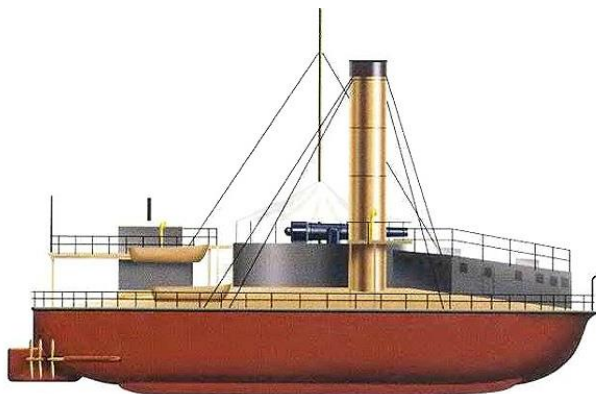

She was laid down on 17 December, 1871 and launched on 21 May, 1873. Commissioned in 1874, she was a monitor class ship armed with two 11-inch guns which could be aimed independently or to fire in salvo. She had a number of other guns as well.

She had a displacement of 2149 tons and was 30.8 metres long.

Her principal design feature was also her Achilles' heel. She was designed to be a particularly stable gun platform and proved to be anything but stable. She rolled and pitched abominably even in a moderate swell.

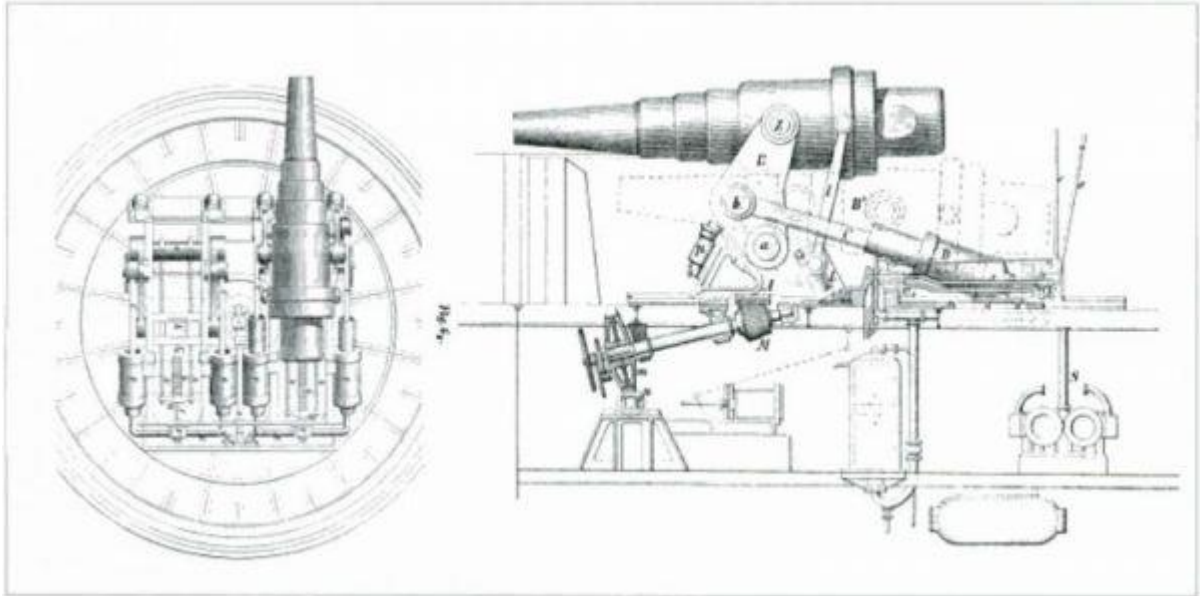

She was decommissioned on 4 July, 1903 and scrapped in 1912.

What was her name and what was her salient feature? This particular feature was partially copied into the design of a royal yacht.

Mark Windward Ten Minute Club

Any yacht that finishes within 10 minutes of the winner can join the Mark Windward Ten Minute Club. After 11 completed races there are 45 yachts that have made it into this elite group. The following table shows that 3 yachts have a 100% record qualifying for the Club every race they've completed.

YACHT	Nos of Races	Nos of times within 10 Minutes of Winner	Success Rate %
BELLABLU	5	5	100.00%
CRACKERJACK	1	1	100.00%
WICKED	5	5	100.00%
WIND SPEED	10	9	90.00%
BARNSTORMER	8	7	87.50%
INSX	8	7	87.50%
WHITE NOISE	7	6	85.71%
MUSKETEER	6	5	83.33%
MAGIC	11	9	81.82%
38 DEGREES SOUTH	5	4	80.00%
WAVELENGTH	5	4	80.00%

YACHT	Nos of Races	Nos of times within 10 Minutes of Winner	Success Rate %
UPBEAT	7	5	71.43%
PRIMO	10	7	70.00%
ARABESQUE	6	4	66.67%
K-YACHT-IC	3	2	66.67%
SALTSHAKER	11	7	63.64%
ALIBI	8	5	62.50%
FORZADO	10	6	60.00%
LEBROK	10	6	60.00%
PIPPA	5	3	60.00%
SALT WHISTLE	10	6	60.00%
SECOND NATURE	10	6	60.00%
STAMPEDE	10	6	60.00%
ADRENALIN	7	4	57.14%
TRESOR	7	4	57.14%
TEQUILA	9	5	55.56%
AIRWAVES	10	5	50.00%
AQUA BELLA	4	2	50.00%
CASSANDRA MELBOURNE	8	4	50.00%
ESPRIT	4	2	50.00%
MORE NOISE	4	2	50.00%
THE SECRETARY	4	2	50.00%
PUBLIC BAR	11	5	45.45%
CAVALIER	9	4	44.44%
FOGGY DEW	9	4	44.44%
JOHNNY B. GOODE	10	4	40.00%
FAST COMPANY	9	3	33.33%
FIREFOX	6	2	33.33%
SURI	6	2	33.33%
ULUWATU	9	3	33.33%
MOANA	10	3	30.00%
MIDNIGHT MAGIC	7	2	28.57%
PIAZZ	7	2	28.57%
CHEQUEMATE	4	1	25.00%
WILLARIE	4	1	25.00%

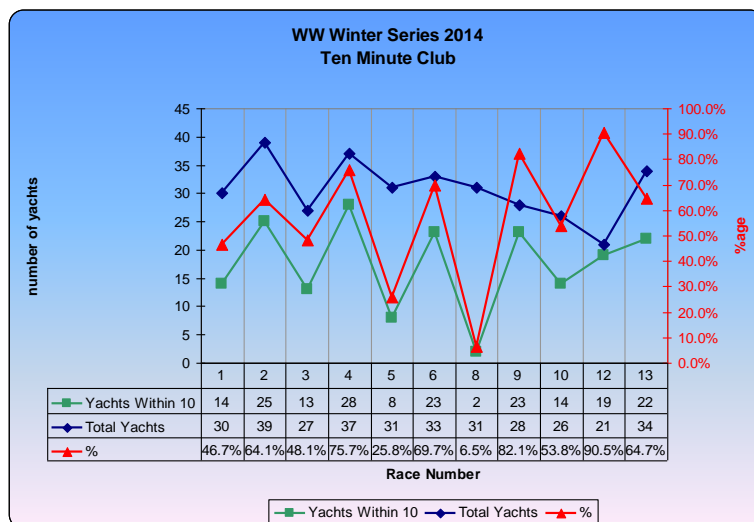

Collecting data for the Ten Minute Club places the spotlight on the number of yachts that qualify in each race. To some degree this measures the effectiveness of handicaps. In race 12 nineteen or 90.5% of twenty yachts finished within 10

minutes of the winner suggesting very good handicapping. In race 8 only two of 31 yachts finished 10 minutes of the winner.

From the Archives 10 years Ago

Race 13 in the Wednesday Wonders Winter 2004 Series was contested by 23 yachts - significantly less than the race 13 in this series. However, some of the yachts and skippers sailing 10 years ago can be found sailing on Wednesday afternoons ten years later. Winning the 2004 race was PIPPA skippered by Jeffrey Woolhouse. Jeffrey was one of 9 skippers sailing in 2004 and still sailing in the current series. Some of the 9 now have different boats and some are sailing as crew on other yachts but 6 of the yachts are still regular competitors. The result of that race was:

Place	Sail No	Boat Name	Skipper
1	SM303	PIPPA	J WOOLHOUSE
2	SM4007	FIRST MUSKETEER	P JACKA
3	SM13	CHIMERE	G BEST
4	AUS219	ULTIMATE TUNE	E WALL-SMITH
5	SM391	OCEAN WARRIOR	G TATE
6	SM16	MYUNA	M STOKOE
7	SM9000	TARDIS	P CHIODO
8	SM367	LEBROK	T KORBEL
9	SM8008	A CREWED INTEREST	R BLINT
10	SM1101	MIDNIGHT MAGIC	B MOORE
11	SM385	FIRE FOX	K BEVERIDGE
12	SM370	DEJA VU	P DRANSFIELD
13	SM371	BOOTS	G SHAW
14	SM747	FLIGHT	P MENTIPLAY
15	SM616	MAGIC	P SPRY-BAILEY
16	SM911	CARRERA	J SIMPSON
17	SM3731	ENCHANTE'	S GALL
18	SM3540	CHEQUEMATE	I WHITBREAD
19	SM337	MISTY BLUE	B CORUM
20	SM773	MILES AHEAD	L CALDER
21	SM246	MOANA	S RANKIN
DNF	SM147	SOULMATE	J HOPE
DNF	SM573	PUBLIC BAR	C SONDEHEIM

Comments, photos etc to mark-windward@live.com.au